

Single 10M Prodigy™ Logic System

The Single S10 10M Prodigy Logic System is a complete and modular prototyping platform based on Intel's Stratix 10 GX 10M FPGA. The system has 1,184 general purpose I/Os and 40 high-speed transceivers on 10 high performance connectors. The Single S10 10M Prodigy Logic System is well suited for next generation 5G, AI, Networking and system validation of complex SoC designs.

S2C's 6th generation Prodigy Player Pro™ Software technology streamlines the design compilation and enables users to perform an array of runtime features remotely through both USB and Ethernet port. Users also have access to a rich portfolio of Prototype Ready IP in the form of plug-play daughter cards to quickly build prototyping targets.

Highlights

- Highest Logic Density with up to 10.2 million Logic Elements
- 40 high-speed transceivers that can run up to 16Gbps
- Abundant high-performance I/Os ease the application extension
- Compatible with over 80 Prodigy Daughter-Card Library
- Complete software-stack eases the design compilation, runtime control and system debug effort



Features

Large Capacity & Scalability

- 10.2M Logic Elements
- 253Mb M20K memory
- 3,456 DSP blocks (6,912 18x19 multipliers)
- Two on-board DDR4 SO-DIMM sockets, each supports up to 72-bit 16GB DDR4
- Multiple systems can be conveniently connected to prototype even larger designs

High Performance

- Up to 180W of power for an FPGA
- Equal trace length for I/Os from same I/O connector
- 40 high-speed transceivers can run up to 16Gbps

Flexible & Powerful I/Os

- 1,152 high-performance I/O pins and 24 high-speed transceivers through 8 Prodigy Connectors
- I/O voltage can be adjusted to 1.2V, 1.35V, 1.5V or 1.8V through runtime software in GUI with 4 status LEDs on-board to indicate I/O voltage
- 16 high-speed transceivers and 32 GPIOs through 2 PGT Connectors

High Reliability

- Screw-lock design to high-speed I/O connectors
- Self-Tests - Isolate design issues from board issues conveniently with a software GUI
- Monitoring of on-board voltage, current and temperature with a software GUI
- Automatic shut-down upon detection of over-current, over-voltage or over-temperatures

Features

Advanced Clock Management

Single-System Mode

- 6 global clocks can be selected from
 - 6 programmable clock sources (0.16 ~ 350MHz)
 - 5 pairs of external clocks through MMCX connectors
 - 1 OSC socket
- Two dedicated programmable clocks for the on-board DDR4 memories
- 3 design clock outputs through 3 pairs of MMCX connectors
- 2 global resets sourced from push button or MMCX or runtime
- 1 global reset sourced from push button

Multi-System Mode

- 6 global clocks to be selected from
 - 6 local programmable clock sources (0.16 ~ 350MHz)
 - 6 global clock sources
- 3 feedback clocks can be output to global clock sources
- 2 global resets sourced from global reset sources

Ease-of-Use

- Auto partitioning the design to multiple dies and multiple FPGAs with Prodigy Player Pro Compile
- Multiple FPGA configuration options through Ethernet port, USB port, JTAG and micro SD card
- Remote power on / off / recycle through Ethernet
- Auto detection of daughter cards and cables
- Virtual SWs & LEDs for simple tasks such as changing a setting or indicating a condition remotely
- User Test Area - LEDs, Push Buttons, Switches and Pin Headers for testing and debugging
- Optional on-board battery charging circuit makes FPGA bin file encryption easy
- Compatible with S2C's off-the-shelf pre-tested daughter boards
- Optional ProtoBridge™ AXI software providing a high-throughput data channel of up to 4,000MB/s
- Optional Prodigy Multi-Debug Module (MDM) for deep trace debugging of multiple FPGAs

I/O Architecture

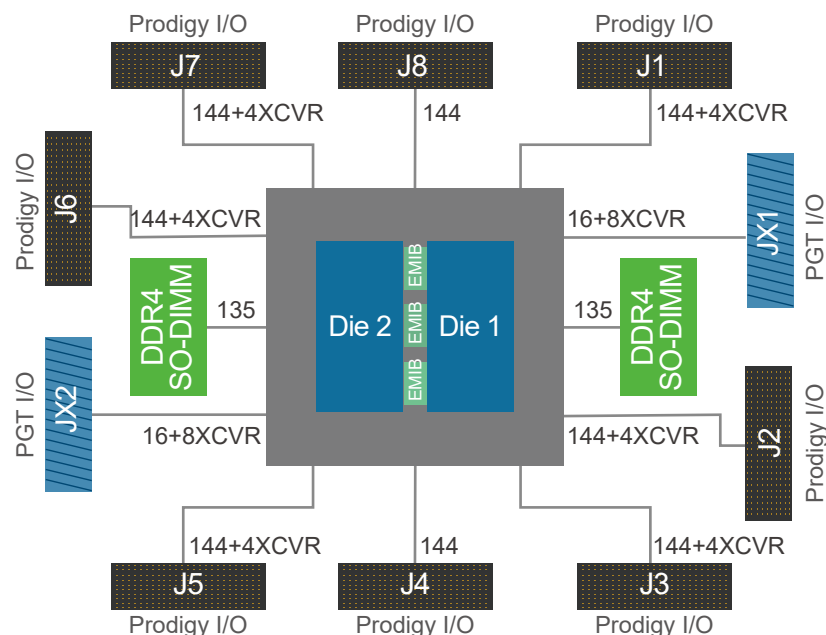

* Data Interface Bus via EMIB, delivers up to 23,040 interconnections